



# The Defense Health Agency: Moving from Transition to Execution

LTG Telita Crosland  
September 11, 2023

## The Defense Health Agency: An Integrated Health System

<p><b>Health Care Delivery System</b> "Medical Force Training Platform and Health Care Provider"</p> <table border="1"> <tr><td> </td><td> </td></tr> <tr><td> </td><td> </td></tr> <tr><td> </td><td> </td></tr> <tr><td> </td><td> </td></tr> <tr><td> </td><td> </td></tr> <tr><td> </td><td> </td></tr> <tr><td> </td><td> </td></tr> <tr><td> </td><td> </td></tr> <tr><td> </td><td> </td></tr> <tr><td> </td><td> </td></tr> </table>																					<p><b>Health Benefits Administrator</b> "Employer Benefits Provider"</p> <p>2.34M &gt;65 Retiree Family Me. 3.17M &lt;65 Retiree Family Me. 1.41M Active Duty 1.64M AD Family Members 0.43M Guard/Reserve 14M Guard/Reserve Family Members</p>	<p><b>TRICARE Suite</b> "Payer"</p> <p><b>Civilian Network Care Contracts</b></p> <ul style="list-style-type: none"> <li>Two medical regions/contractors in US             <ul style="list-style-type: none"> <li>Health Net (West) &amp; Humana (East)</li> </ul> </li> <li>One international medical benefits contractor             <ul style="list-style-type: none"> <li>International SOS</li> </ul> </li> <li>One pharmacy benefit contractor             <ul style="list-style-type: none"> <li>Express Scripts</li> </ul> </li> <li>One dental program contractor             <ul style="list-style-type: none"> <li>United Concordia</li> </ul> </li> </ul> <p><b>TRICARE Benefit Plan Options</b></p> <ul style="list-style-type: none"> <li>TRICARE Prime</li> <li>TRICARE Select</li> <li>TRICARE for Life</li> <li>TRICARE Reserve Select</li> <li>TRICARE Retired Reserve</li> <li>US Family Health Plan</li> <li>TRICARE Young Adult</li> <li>Active Duty Dental</li> <li>TRICARE Dental</li> <li>FEDVIP</li> </ul>
<p><b>Combat Support Agency</b> "Partner"</p>																						
<p><b>Joint Medical Logistics</b></p> <ul style="list-style-type: none"> <li>Identify and deliver medical materiel solutions to meet operational requirements</li> </ul>	<p><b>Research &amp; Development</b></p> <ul style="list-style-type: none"> <li>Provide novel medical tools, techniques, and clinical practice guidelines to modernize MHS capabilities for near-peer conflict</li> </ul>	<p><b>Global Public Health</b></p> <ul style="list-style-type: none"> <li>Provide combatant commands with near real-time disease and bio-surveillance threat information</li> </ul>	<p><b>Education &amp; Training</b></p> <ul style="list-style-type: none"> <li>Build and sustain a ready medical force through Medical Education &amp; Training Campus and MTF platforms</li> </ul>	<p><b>Joint Trauma System</b></p> <ul style="list-style-type: none"> <li>Maximize battlefield injury survival functional recovery rates</li> </ul>																		

# DHA Mission, Vision & Priorities



**MISSION:**

The Defense Health Agency supports our Nation by improving health and building readiness – making extraordinary experiences ordinary and exceptional outcomes routine.



**VISION:**

Unrelenting pursuit of excellence as we care for our joint force and those that we are privileged to serve. Anytime, Anywhere-Always



**PRIORITIES:**

- Enabling Combat Support to the Joint Force in Competition, Crisis, or Conflict
- Building a Modernized, Integrated, and Resilient Healthcare Delivery System
- Dedicated and Inspired Teams of Professionals Driving Military Health's Next Evolution



*Improving Health and Building Readiness. Anytime, Anywhere — Always*



# New Defense Health Network Structure

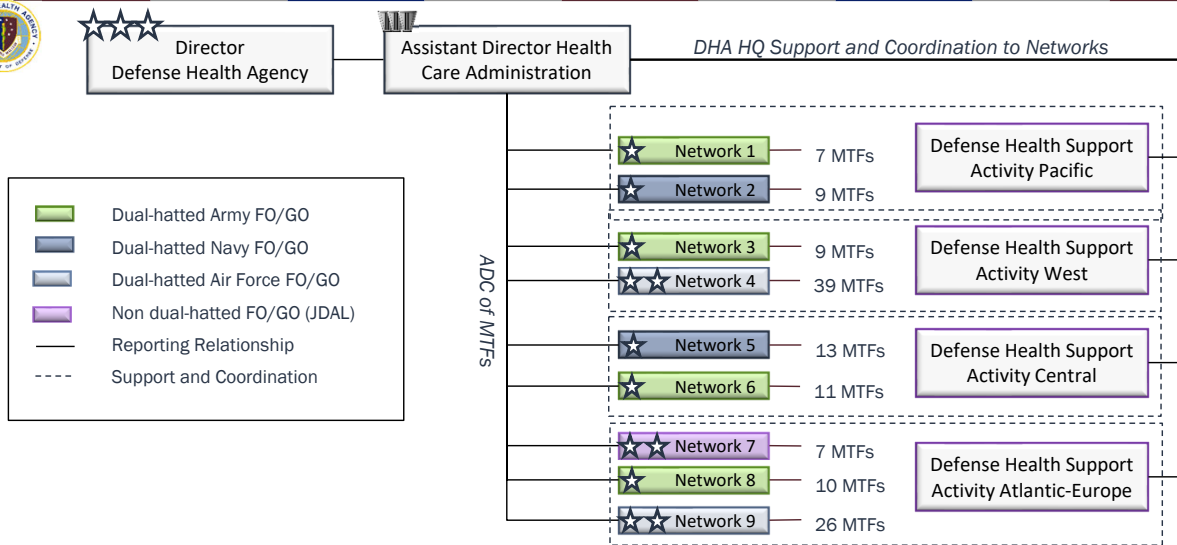

*Improving Health and Building Readiness. Anytime, Anywhere — Always*



## MTF Priority Efforts

- **Quality & safety first**, the cornerstone and foundation of every MTF in the DHA
- **Align resources and manage behaviors** to generate the greatest impact on the mission while achieving business plans
- **Standardize processes** to reduce template variation and implement appointing processes that are person-centric, not system-centric
- **Optimize adoption of MHS GENESIS** and exploit agile, new capabilities in support of access, quality, and safety
- **Focus on people**, including hiring, onboarding, training & retention



*Improving Health and Building Readiness. Anytime, Anywhere — Always*



## Major Efforts to Advance Medical Readiness & Improve Healthcare Delivery in MTFs

Deliver More Complex Care in Large MTFs & Augment Primary Care Capacity at Smaller MTFs

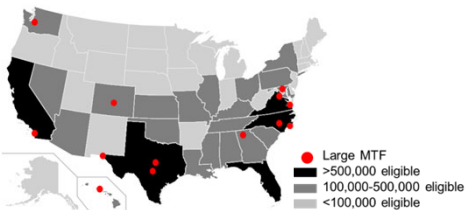

Maximize Existing Hiring Authorities and Salary Caps & Reduce Time to Hire



Expand Partnerships with Dept. of Veterans Affairs (VA) and Civilian Partners

Locations with near-term opportunities for collaboration

DHA MTF	VA VISN / Network
Joint Base Elmendorf-Richardson	20 / VA Alaska Healthcare
NMC Portsmouth	6 / VA Hampton Healthcare
Madigan AMC	20 / Seattle VAHCS
Eglin AFB & NH Jacksonville	16 / Gulf Coast Veterans HCS
MacDill AFB	8 / VA Tampa HCS
Evans ACH & USAF Academy	19 / VA Eastern CO HCS
Blanchfield ACH	9 / VA TN Valley HCS



Behavioral Health Appointments (FY22)

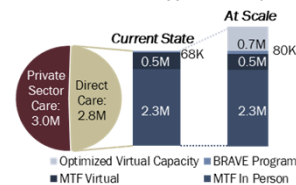

*Improving Health and Building Readiness. Anytime, Anywhere — Always*



## DHA Core Values



### Dependability

We are trustworthy, honest about our performance, and follow through on our commitments

### Humility

We focus on listening, we are compassionate, and we take an active interest in understanding the needs and concerns of our teammates, partners, and patients

### Agility

We adapt quickly and innovate effectively when presented with new opportunities and new challenges



*Improving Health and Building Readiness. Anytime, Anywhere — Always*

